

34. The school playground, a 36 m square, is going to lose part of one corner due to construction. The city will take a triangular section that measures 12 m and 12 m on the perpendicular sides.

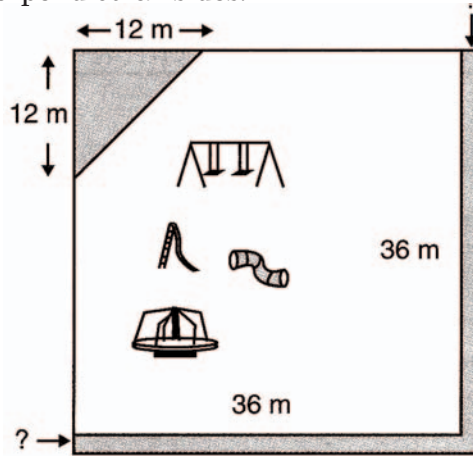

The city has agreed to allow the school to expand the playground on the remaining two sides to replace the lost area.

Find the approximate width of the strip that will be added to each of the two sides.

Show your work using words, numbers and/or diagrams.

Approximate width of the strip is _____

Scoring Rubric

High School Mathematics Practice Test Item 34	
Strand: Measurement	
ME03	Learning Target: (Procedures) Use formulas, including the Pythagorean Theorem, to determine measurements of triangles, prisms, or cylinders (1.2.5)
<p>A 2-point response: The student demonstrates an understanding of measurement by showing how to compute the area of a triangle (72 square meters) and find the width (approximately 1 meter) of two rectangles that are 36 meters long and have an area approximately equal to the area of the triangle.</p> <p>A 1-point response: The student does one of the following:</p> <ul style="list-style-type: none">• Shows the computation of the area of the triangle (72 square meters)• Finds the approximate dimension of the width of the rectangle, which is 1 meter• Uses the area of a square rather than a triangle and arrives at an incorrect width of 2 meters. <p>A 0-point response: The student shows no understanding of how to compute the area of a triangle or how to find the width of the rectangular piece of land with a given length and area.</p>	

34. The school playground, a 36 m square, is going to lose part of one corner due to construction. The city will take a triangular section that measures 12 m and 12 m on the perpendicular sides.

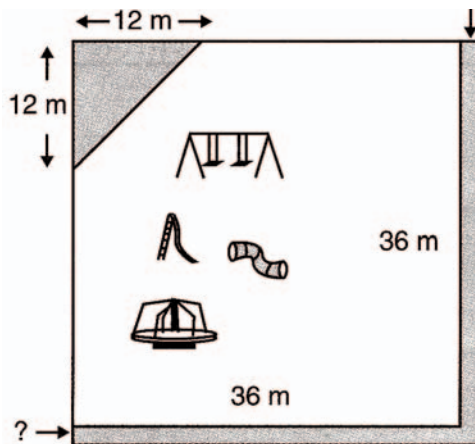

The city has agreed to allow the school to expand the playground on the remaining two sides to replace the lost area.

Find the approximate width of the strip that will be added to each of the two sides.

Show your work using words, numbers and/or diagrams.

$12 \times 12 = 144 \div 2 = 72$
 $36 \times 2 = 72$
 w of strip ≈ 1 m
 The area they're losing is 72 m^2 .
 The approximate length of the strip is 72 m , therefore the width only needs to be 1 m .
 Approximate width of the strip is 1 m

Score:

2

Annotation:

The student shows understanding of determining the area of a triangle and finding the width of two rectangles whose total area is approximately the same as the triangle. The run-on equation cannot be used as support but the student recovers in the written work. The response shows a width of 1 m. This response earns two points.

34. The school playground, a 36 m square, is going to lose part of one corner due to construction. The city will take a triangular section that measures 12 m and 12 m on the perpendicular sides.

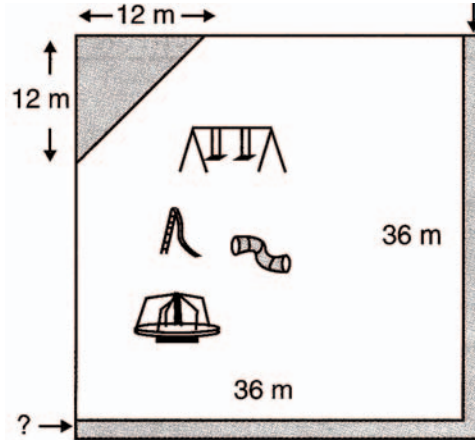

The city has agreed to allow the school to expand the playground on the remaining two sides to replace the lost area.

Find the approximate width of the strip that will be added to each of the two sides.

Show your work using words, numbers and/or diagrams.

$$\frac{12 \times 12}{2} = 72$$

$$\frac{72}{2} = 36x$$

$$\frac{72}{72} = \frac{72x}{72}$$

$$1 = x$$

First you find the area of the triangle to know what the area is going to be. Then you divide it by 2 and make it equal to $36 \cdot x$, which is one of the added sides. After multiplying and dividing you get 1, but because of that little extra square, it is actually slightly below one.

Approximate width of the strip is 1 or .9

Score:

2

Annotation:

The student shows understanding of determining the area of a triangle and finding the width of two rectangles whose total area is approximately the same as the triangle. The response shows width of "1 or .9." This response earns two points.

34. The school playground, a 36 m square, is going to lose part of one corner due to construction. The city will take a triangular section that measures 12 m and 12 m on the perpendicular sides.

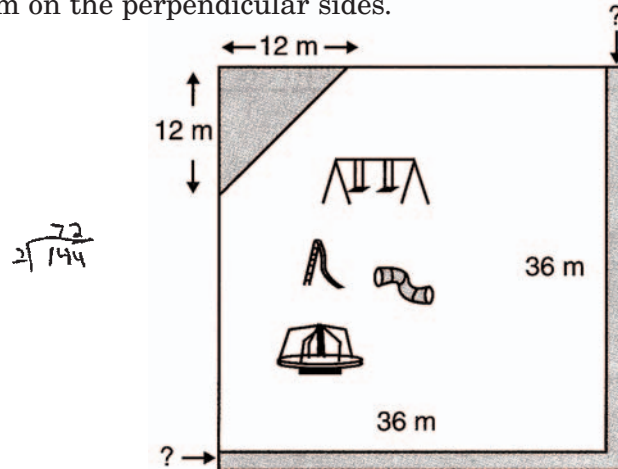

The city has agreed to allow the school to expand the playground on the remaining two sides to replace the lost area.

Find the approximate width of the strip that will be added to each of the two sides.

Show your work using words, numbers and/or diagrams.

$A = \frac{1}{2}bh$ $\frac{36}{2 \cdot 72}$
 $A = 72m^2$ $\frac{72}{12}$

The area of the missing triangle is 72, divide by 2 is 36 so the width of the strip is 4

Approximate width of the strip is 4

Score:

1

Annotation:

The student shows partial understanding of determining the area of a triangle and finding the width of two rectangles whose total area is approximately the same as the triangle. The response shows an incorrect width of 4. This response earns one point.

34. The school playground, a 36 m square, is going to lose part of one corner due to construction. The city will take a triangular section that measures 12 m and 12 m on the perpendicular sides.

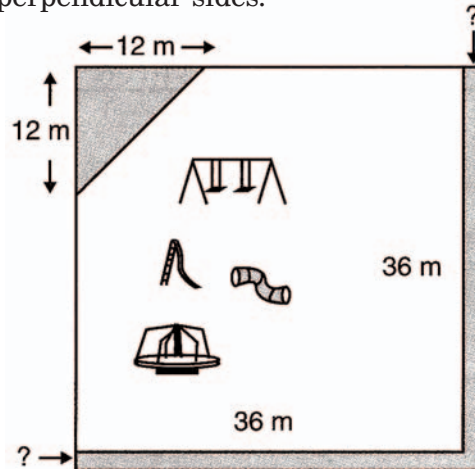

The city has agreed to allow the school to expand the playground on the remaining two sides to replace the lost area.

Find the approximate width of the strip that will be added to each of the two sides.

Show your work using words, numbers and/or diagrams.

Approximate width of the strip is <u>1 m</u>

Score:
1

Annotation:
The student shows partial understanding of determining the area of a triangle and finding the width of two rectangles whose total area is approximately the same as the triangle. The response shows a correct width of 1 m but does not provide supporting work. This response earns one point.

34. The school playground, a 36 m square, is going to lose part of one corner due to construction. The city will take a triangular section that measures 12 m and 12 m on the perpendicular sides.

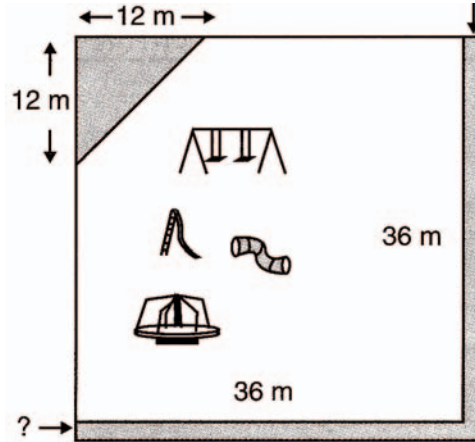

The city has agreed to allow the school to expand the playground on the remaining two sides to replace the lost area.

Find the approximate width of the strip that will be added to each of the two sides.

Show your work using words, numbers, and/or diagrams.

$\frac{12}{6} = 2\text{ m}$
 ← ADDED STRIP
 CUT OFF TRIANGLE
 If you take the added strip and measure it by eye then go to the triangle and see how many times it fits in 12m you get 6 but the triangle is 12m not 6 so $12 \div 6 = 2$ and that is the width of the strip.
 Approximate width of the strip is 2 m

Score:
0

Annotation:
The student shows little or no understanding of determining the area of a triangle and finding the width of two rectangles whose total area approximately is the same as the triangle. The response shows an incorrect width of 2 m and no relevant supporting work. This response earns zero points.

34. The school playground, a 36 m square, is going to lose part of one corner due to construction. The city will take a triangular section that measures 12 m and 12 m on the perpendicular sides.

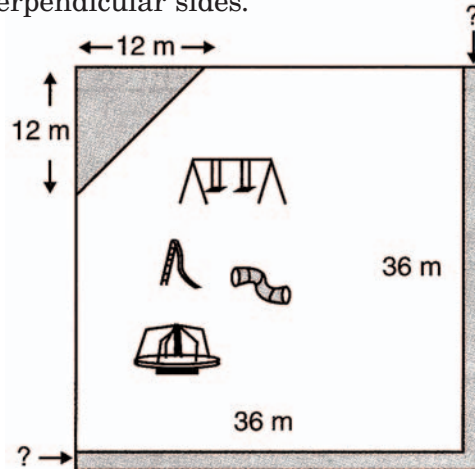

The city has agreed to allow the school to expand the playground on the remaining two sides to replace the lost area.

Find the approximate width of the strip that will be added to each of the two sides.

Show your work using words, numbers and/or diagrams.

$12 \overline{) 36}$
Approximate width of the strip is: <u>3 m</u>

Score:

0

Annotation:

The student shows little or no understanding of determining the area of a triangle and finding the width of two rectangles whose total area approximately is the same as the triangle. The response shows an incorrect width of 3 m and no relevant supporting work. This response earns zero points.

34. The school playground, a 36 m square, is going to lose part of one corner due to construction. The city will take a triangular section that measures 12 m and 12 m on the perpendicular sides.

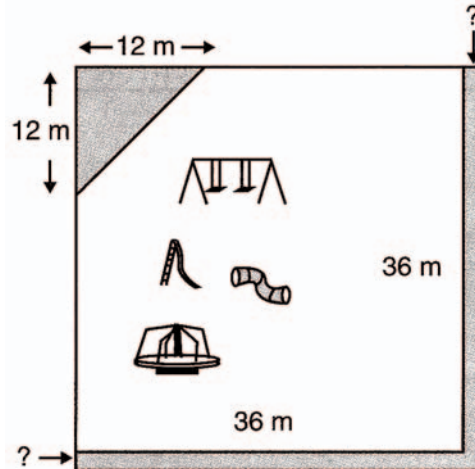

The city has agreed to allow the school to expand the playground on the remaining two sides to replace the lost area.

Find the approximate width of the strip that will be added to each of the two sides.

Show your work using words, numbers and/or diagrams.

36 by 36 taking off 12
by 12 will leave them
with 24 by 24 you can
add 6 by 6 to make
it 30 by 30
Approximate width of the strip is <u>6 m</u>

Score:

0

Annotation:

The student shows little or no understanding of determining the area of a triangle and finding the width of two rectangles whose total area approximately is the same as the triangle. The response shows an incorrect width of 3 m and no relevant supporting work. This response earns zero points.

